

### MONTAGEWERKZEUGE

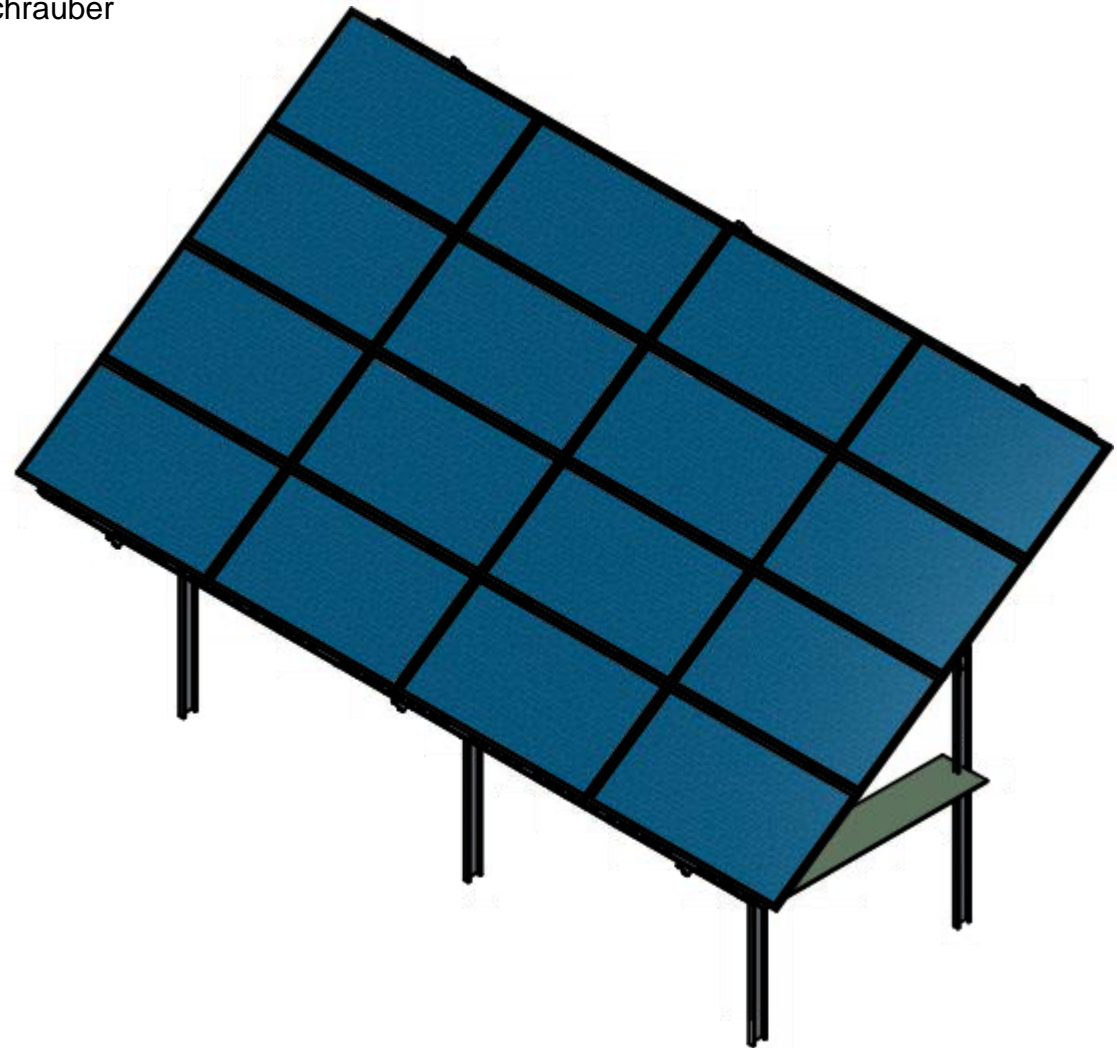

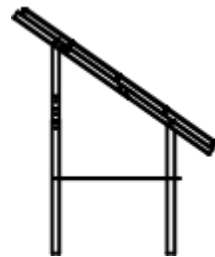
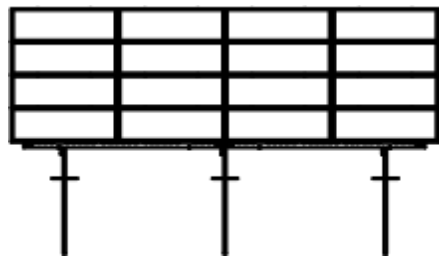

Distributed by

**SCHERL**  
ELEKTRO

www.scherl-elektro.at

## ASSEMBLY INSTRUCTION

Schützen zum Einschlagen oder  
eibetonieren

### FL-58 UNIVERSAL

Montageanleitung

NORDEN „N“

WESTEN „W“

B ( 1 : 5 )

OSTEN „E“

Boden

A ( 1 : 5 )

A

Hintere Stütze

Boden

Hintere Stütze

Vordere Stütze

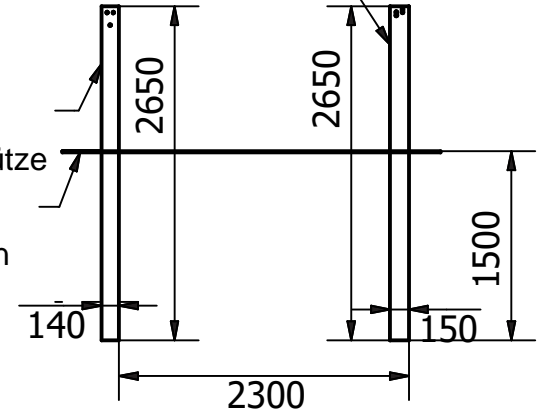

Vordere Stütze

B

**ACHTUNG!!!** Achten Sie bitte auf die korrekte Montage der Stützen.



Distributed by

**SCHERL**  
ELEKTRO

www.scherl-elektro.at

# FL-58 UNIVERSAL

Montageanleitung

## ASSEMBLY INSTRUCTION

Montage der Tragkonstruktion

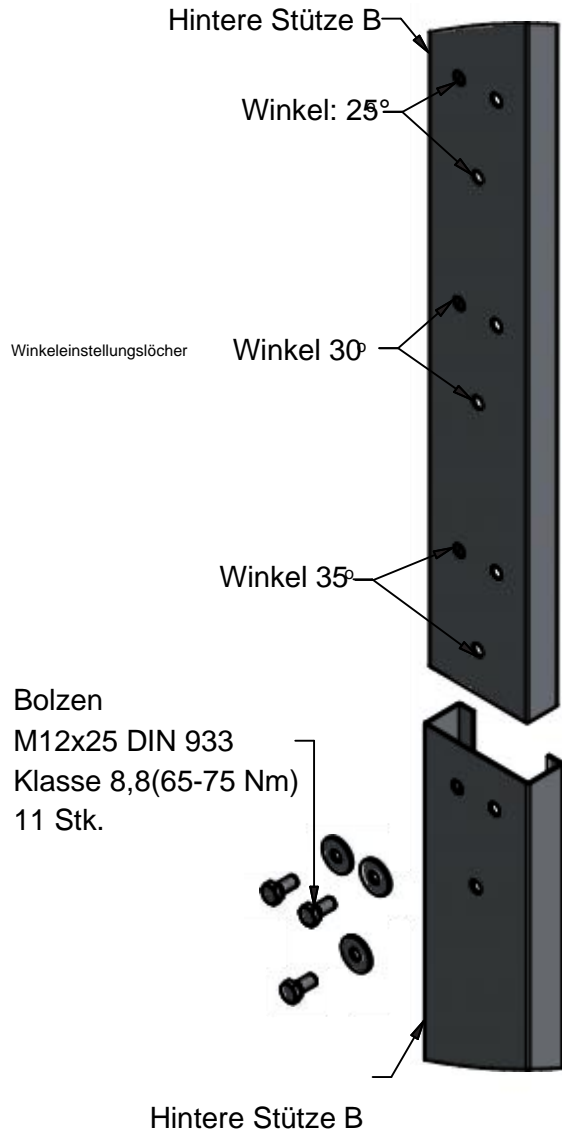

A ( 1 : 7 )

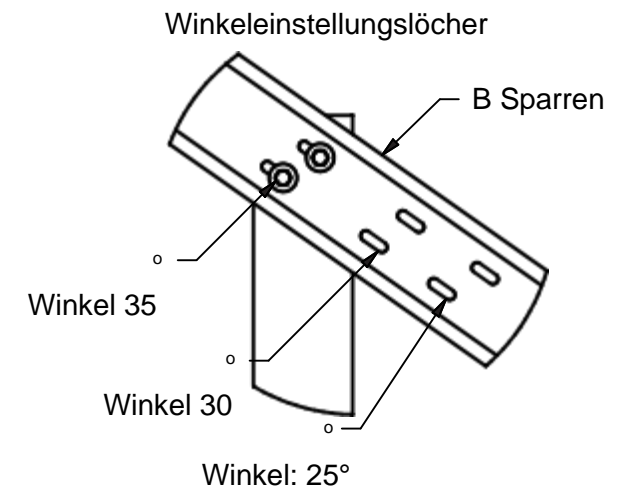
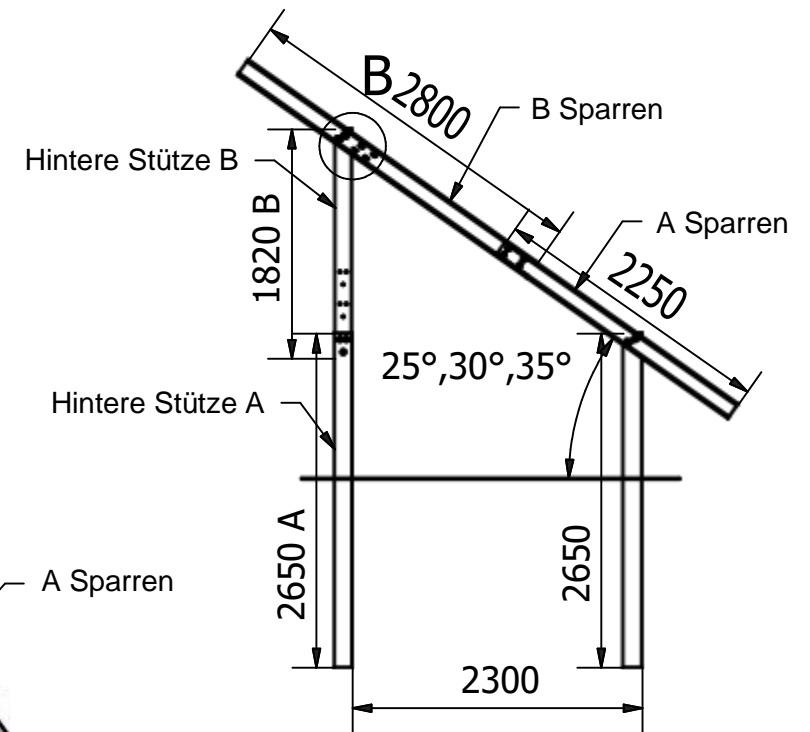
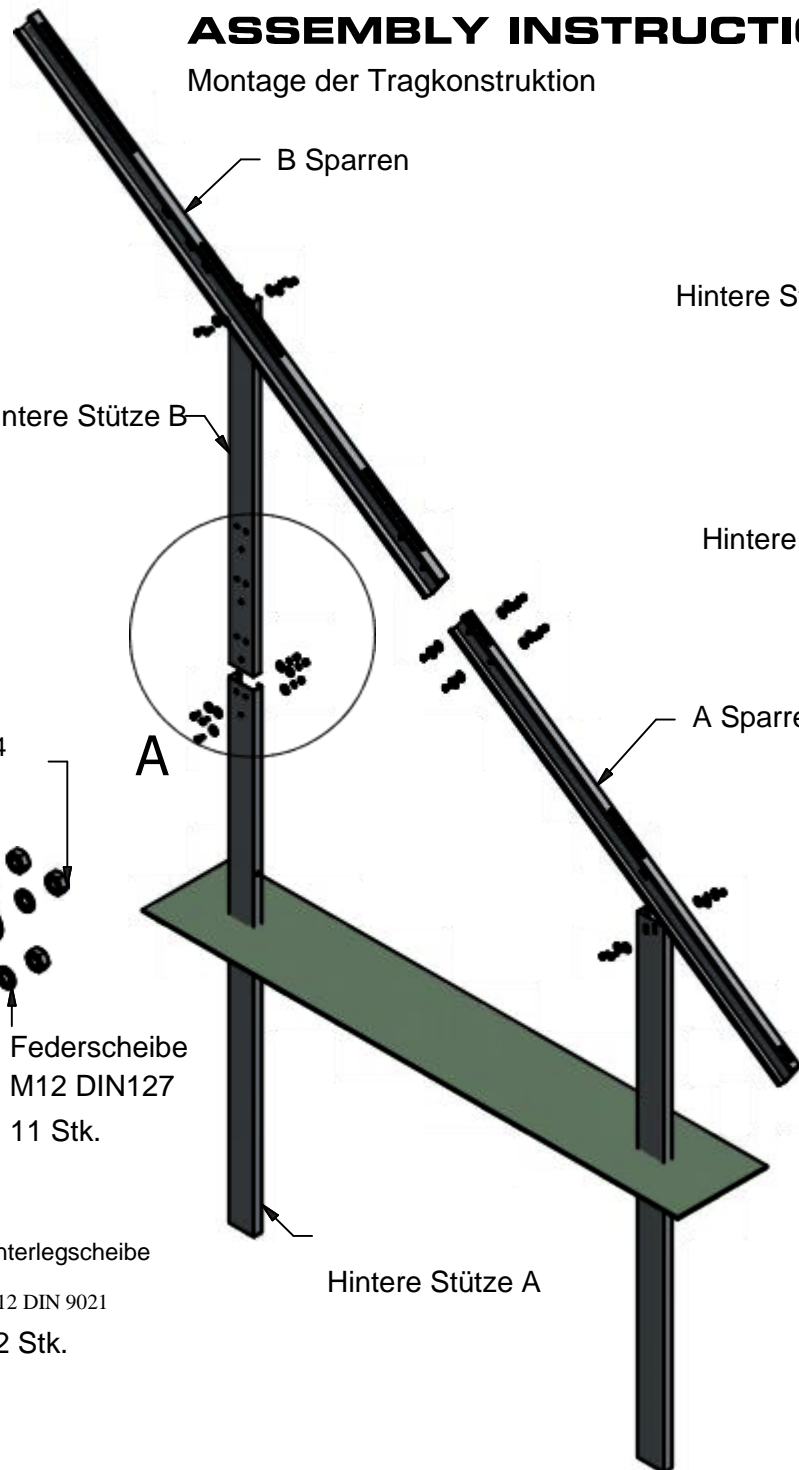
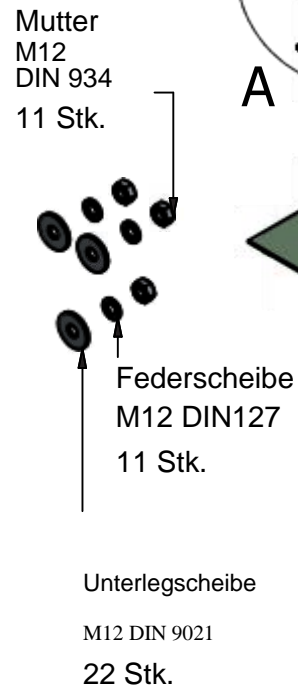

B ( 1 : 10 )

# ASSEMBLY INSTRUCTION

Montage der Pfetten

# FL-58 UNIVERSAL

Montageanleitung

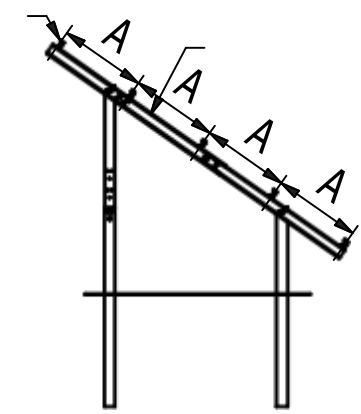
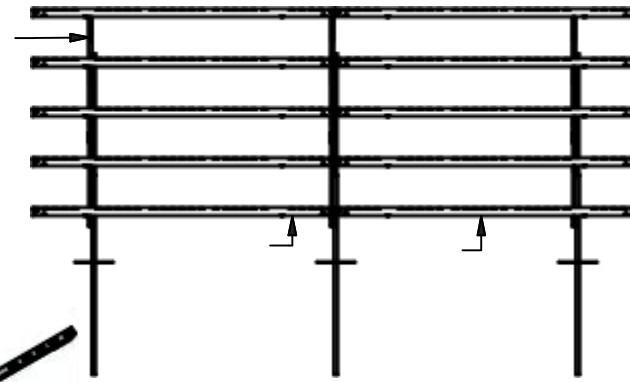
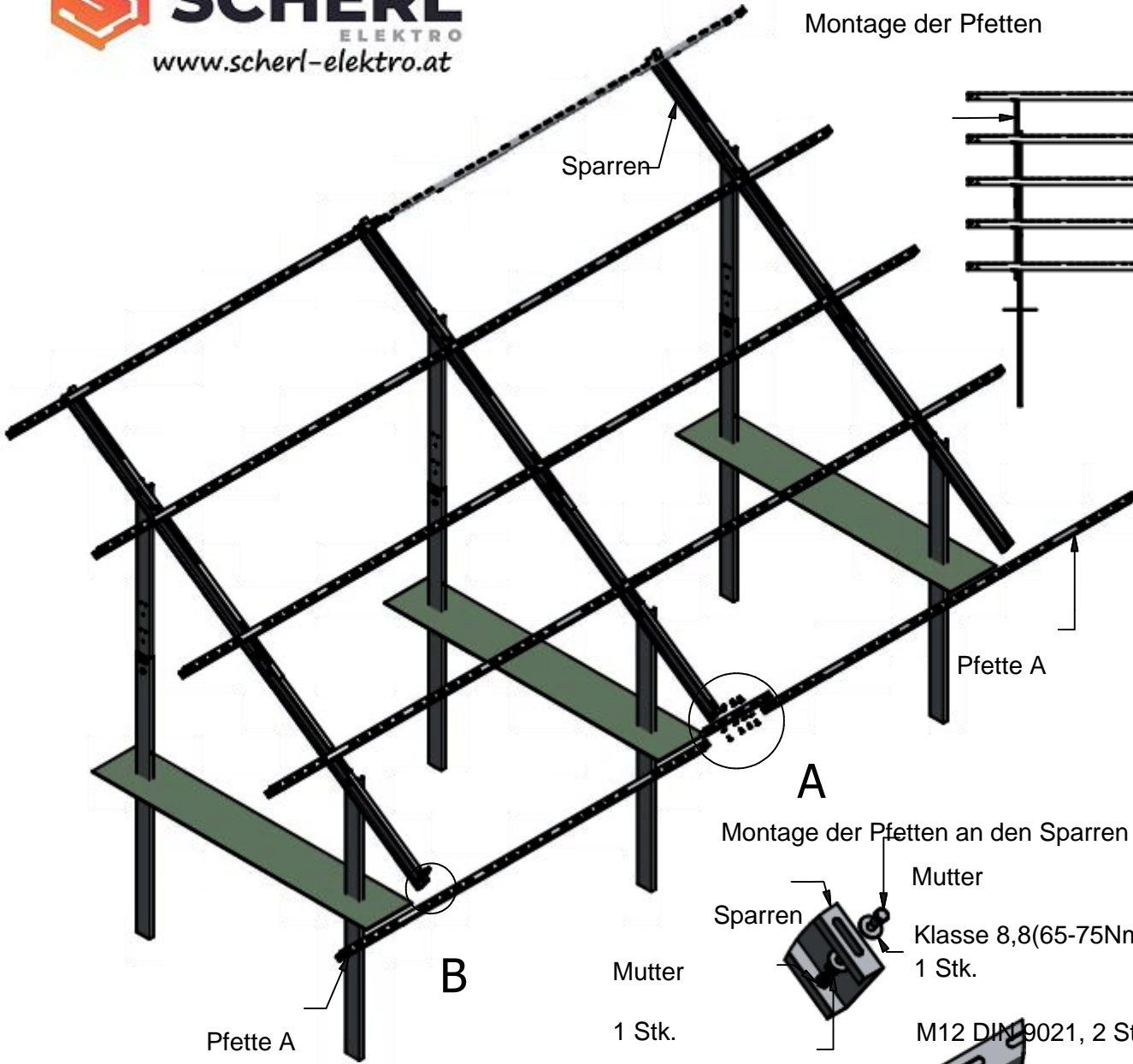

**A**  
 Montage der Pfetten an den Sparren

- Mutter 1 Stk.
- Klasse 8,8(65-75Nm)
- M12 DIN 9021, 2 Stk.

**B (1:10)**

**A (1:7)**

Verbinden der Pfetten

- Mutter M12 DIN 934 4 Stk.
- Federscheibe M12 DIN127 4 Stk.
- Verbinden der Pfetten
- Kleine Module
- Pfette A
- Verbinden der Pfetten
- Große Module
- Unterlegscheibe
- Mutter 8 Stk.
- Pfette A Klasse 8,8(6575Nm) 4 Stk.



Distributed by

**SCHERL**  
ELEKTRO  
www.scherl-elektro.at

# ASSEMBLY INSTRUCTION

Montage der Module

# FL-58 UNIVERSAL

Montageanleitung

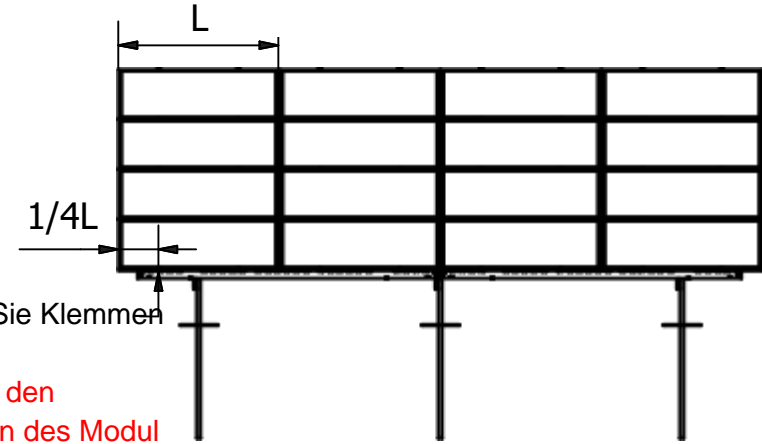
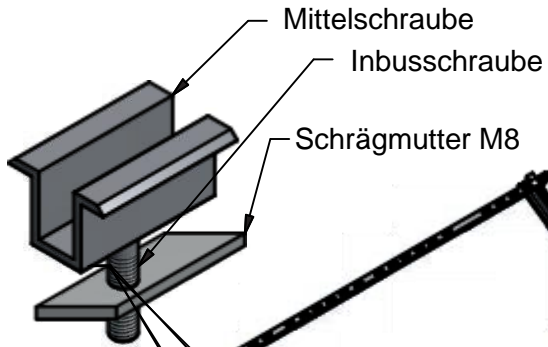

Installieren Sie Klemmen  
(1/4 L)  
oder gemäß den  
Anweisungen des Modul  
Herstellers.

Montage des Klemmensatzes  
(in einem Winkel einsetzen)

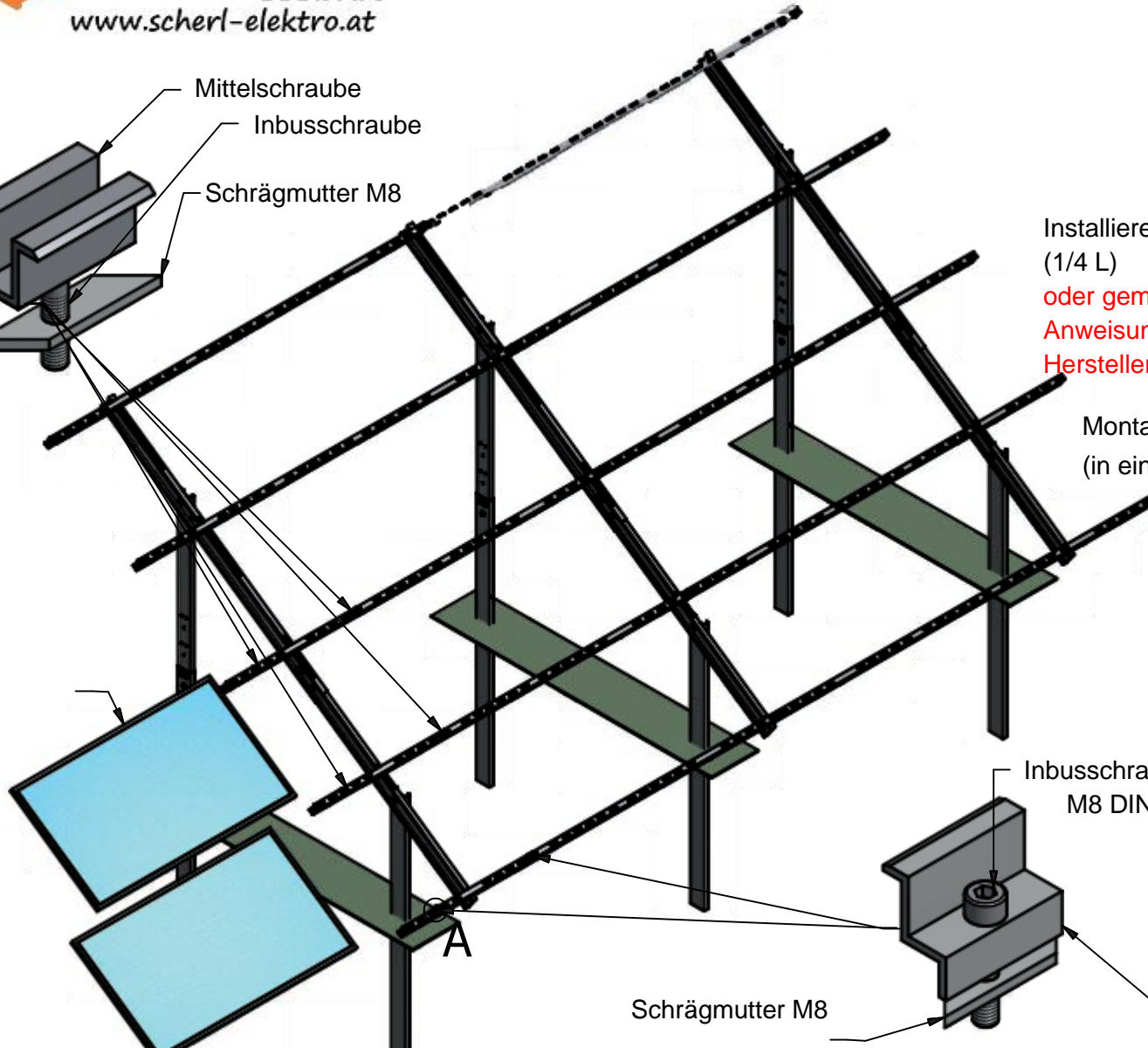
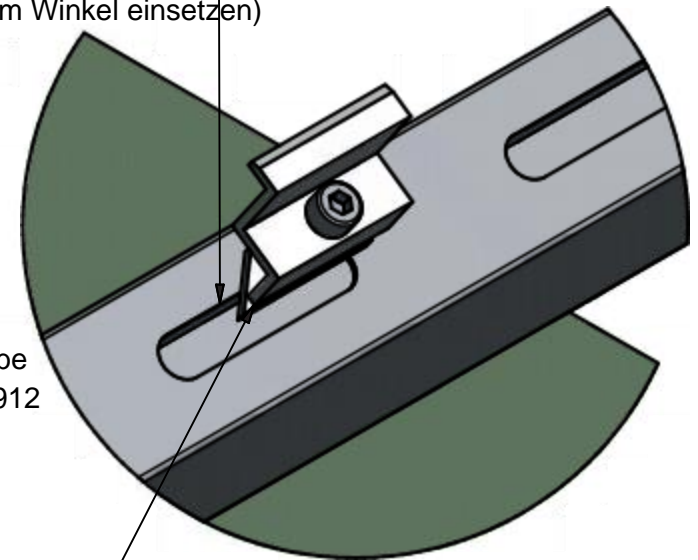

Hinweis: Installieren Sie die Klemmen auf den Pfetten, bevor Sie die Module installiere  
Achtung! Ziehen Sie die M8 Schrauben mit der Kraft (Nm) gemäß den Montageanweisungen des Herstellers von Modul an.

$\Delta (1:2)$